

PALMGREN®



2" Variable-Speed Belt with Buffer

Model 9681106

®

PALMGREN

**PLEASE READ AND SAVE
THESE INSTRUCTIONS.
READ CAREFULLY
BEFORE ATTEMPTING
TO ASSEMBLE, INSTALL,
OPERATE OR MAINTAIN THE
PRODUCT DESCRIBED.**

**PROTECT YOURSELF AND
OTHERS BY OBSERVING ALL
SAFETY INFORMATION. FAILURE
TO COMPLY WITH INSTRUCTIONS
COULD RESULT IN PERSONAL
INJURY AND/OR PROPERTY
DAMAGE! RETAIN INSTRUCTIONS
FOR FUTURE REFERENCE.**

**PLEASE REFER TO BACK COVER
FOR INFORMATION REGARDING
PALMGREN'S WARRANTY
AND OTHER IMPORTANT
INFORMATION.**

Model #: _____

Serial #: _____

Purch. Date: _____

© 2024 Palmgren Electric Manufacturing Co.
All Rights Reserved

GETTING STARTED

Save this manual

You will need this manual for the safety warnings and precautions, assembly instructions, operating and maintenance procedures, parts lists and diagrams. Keep your invoice with this manual. Write the invoice number on the inside of the front cover. Keep this manual and invoice in a safe and dry place for future reference.

Structural requirements



Make sure all supporting structures and load attaching devices are strong enough to hold your intended loads. If in doubt, consult a qualified structural engineer.

Electrical requirements



The power supply to the belt grinder needs to be 115V/230V, 14A/7A, single phase, 60 Hz. The standard allowable voltage variation is plus or minus 10%.

Tools needed

Standard professional mechanic's hand tool set.

UNPACKING

⚠ WARNING *Be careful not to touch overhead power lines, piping, lighting, etc. if lifting equipment is used. The belt grinder weighs approximately 116 lbs; proper tools, equipment and qualified personnel should be employed in all phases of unpacking and installation.*

Carton should be handled with care to avoid damage from dropping, bumping, etc. Store and unpack carton with correct side up. Unpack all parts from the container. Check for damage as each piece is removed. After unpacking the belt grinder, inspect carefully for any damage that may have occurred during transit. Check for loose, missing or damaged parts. If any damage or loss has occurred, claim must be filed with carrier immediately. Check for completeness. Immediately report missing parts to dealer.

⚠ WARNING *Never use highly volatile solvents. Non flammable solvents are recommended to avoid possible fire hazard. Avoid getting cleaning solution on paint as it may tend to deteriorate these finishes. Use soap and water on painted components.*

IMPORTANT: Many unpainted steel surfaces have been coated with a protectant. To ensure proper fit and operation, remove the coating. Coating can be easily removed with mild solvents, such as mineral spirits, and a soft cloth. Avoid getting solution on paint or any of the rubber/plastic parts. Solvents may deteriorate these finishes. Use soap and water on paint, plastic, or rubber components. After cleaning, cover all exposed surfaces with a light coating of oil.

Package Contents:

- Grinder unit with belt arm and shaft 1x
- Stabilizing bracket x1
- Tool rest assembly bag
- Buffer spacers x4
- Buffer flanges x2
- Belt guard (with eyeshield and dust exhaust port) x1

Unpack



Do not discard packing materials until after machine has been inspected for damage and completeness. Locate loose parts and set aside.

Inspect



After unpacking the unit, carefully inspect for any damage that may have occurred during transit. Check for loose, missing, or damaged parts. Shipping damage claims must be filed with the carrier. Immediately report missing parts to dealer.

All tools should be visually inspected before use, in addition to regular periodic maintenance inspections.

Be sure that the voltage labeled on the unit matches your power supply.



See General Safety Instructions, Cautions and Warnings as shown.

SAFETY RULES

Before repairs, powering on the machine or maintenance, the user must know and follow all safety guidelines.

Clothing and General Use**▲ WARNING**

- For your own safety, read all of the instructions and precautions before operating tool.
- Always follow proper operating procedures as defined in this manual even if you are familiar with the use of this or similar tools. Remember that being careless for even a fraction of a second can result in severe personal injury.
- Wear proper apparel. Do not wear loose clothing, neckties, rings, bracelets or other jewelry which may get caught up in moving parts of machine. Do NOT wear gloves.
- Wear protective hair covering to contain long hair.
- Wear safety shoes with non-slip soles.
- Wear safety glasses complying with United States ANSI Z87.1. Everyday glasses have only impact resistant lenses. They are NOT safety glasses. Use guards and eye shields.
- **PROPOSITION 65 WARNING:** Some dust created by using power tools contain chemicals known to the state of California to cause cancer, birth defects or other reproductive harm. Some examples of these chemicals are:
 - Lead from lead-based paints.
 - Crystalline silica from bricks and cement and other masonry products.
 - Arsenic and chromium from chemically-treated lumber.

Your risk from these exposures varies, depending on how often you do this type of work. To reduce your exposure to these chemicals: work in a well-ventilated area and work with approved safety equipment. Always wear OSHA/NIOSH approved, properly fitting face mask or respirator when using such tools.

- Wear ANSI approved ear protection for extended operation.
- Be alert and think clearly. Never operate power tools when tired, intoxicated or when taking medications that cause drowsiness.
- Focus your attention completely on your work. Looking around, careless actions and other distractions can result in serious injury.

Installation**▲ WARNING**

- Ensure the installation location can support the weight of the machine.
- Do not allow water or other liquids, dust, metal dust or other contaminants to enter the controls or electrical box, otherwise it may cause fires or damage to the machine and surroundings.

▲ CAUTION

- Use the appropriate means to place the machine on work surface.
- When installing, check for adequate space in the install location for the belt grinder.
- When moving to the install location make sure the belt grinder is firmly secured to the lifting means.
- Check that this machine has adequate ventilation and heat dissipation.

Electrical**▲ WARNING**

- Before connecting the machine's power cord to power, check that the power switch is off and that the cord is undamaged.

Operation**▲ WARNING**

Before starting machine check:

- Make sure that the guards are in place and provide adequate visibility.
- Keep the surrounding workspace clean with regular maintenance and cleaning.
- Do not make any changes or modifications to the machine; this could cause an electric shock or personal injury and void the warranty.
- **KEEP GUARDS IN PLACE AND IN WORKING ORDER.**
- **KEEP WORK AREA CLEAN.** Cluttered areas and benches invite accidents.
- **NEVER USE IN DANGEROUS ENVIRONMENT.** Do not use power tools in damp or wet locations, or where any flammable or noxious fumes may exist. Keep work area well lighted.
- **KEEP CHILDREN AND VISITORS AWAY.** All children and visitors should be kept at a safe distance from work area.
- **MAKE WORKSHOP CHILDPROOF** with padlocks, master switches, or by removing starter keys.
- **NEVER FORCE TOOL.** It will do the job better and safer at the rate for which it was designed.
- **USE THE RIGHT TOOL.** Do not force tool or attachment to do a job for which it was not designed.

▲ CAUTION

- Do not plug or unplug line power to the machine while it is running.
- Do not repeatedly turn on and turn off the power switch in a short amount of time. This will damage the machine.
- Deactivate the power before any service or maintenance.
- Only a qualified electrician should check the electric parts.
- Please treat the debris generated during processing as industrial waste to prevent environmental pollution or personal injury.

PREPARING FOR YOUR JOB

- Wear proper apparel. Do not wear loose clothing, gloves, neckties, rings, bracelets, or other jewelry which may get caught in moving parts of machine.
- Wear protective hair covering to contain long hair.
- Wear safety shoes with non-slip soles.
- Wear safety glasses complying with United States ANSI Z87.1. Everyday glasses have only impact resistant lenses. They are NOT safety glasses.
- Wear face mask or dust mask if operation is dusty.
- Be alert and think clearly. Never operate power tools when tired, intoxicated or when taking medications that cause drowsiness.

Prepare Work Area For Job

- Keep work area clean. Cluttered work areas invite accidents.
- Do not use power tools in dangerous environments. Do not use power tools in damp or wet locations. Do not expose power tools to rain.
- Work area should be properly lighted.
- Proper electrical receptacle should be available for tool. Three-prong plug should be plugged directly into properly grounded, three-prong receptacle.
- Extension cords should have a grounding prong and the three wires of the extension cord should be of the correct gauge.
- Keep visitors at a safe distance from work area.
- Keep children out of workplace. Make workshop childproof. Use padlocks, master switches or remove switch keys to prevent any unintentional use of power tools.

Tool Should Be Maintained

- Always unplug tool prior to inspection.
- Consult manual for specific maintaining and adjusting procedures.
- Keep tool lubricated and clean for safest operation.
- Remove adjusting tools. Form habit of checking to see that adjusting tools are removed before switching machine on.
- Keep all parts in working order. Check to determine that the guard or other parts will operate properly and perform their intended function.
- Check for damaged parts. Check for alignment of moving parts, binding, breakage, mounting and any other condition that may affect a tool's operation.
- A guard or other part that is damaged should be properly repaired or replaced. Do not perform makeshift repairs. (Use parts list provided to order repair parts.)

Know How To Use Tool

- Use right tool for job. Do not force tool or attachment to do a job for which it was not designed.
- Disconnect tool when changing abrasive belt.
- NEVER FORCE TOOL. It will do the job better and safer at the rate for which it was designed.
- Use of improper accessories may cause risk of injury to persons.
- Handle workpiece correctly. Protect hands from possible injury.
- Turn machine off if it jams. Belt jams when it digs too deeply into workpiece. (Motor force keeps it stuck in the work.)
- Never leave tool running unattended. Turn power off and do not leave tool until it comes to a complete stop.
- Do not overreach. Keep proper footing and balance.
- Never stand on tool. Serious injury could occur if tool is tipped or if belt is unintentionally contacted.
- Keep hands away from moving parts and sanding surfaces.
- Know your tool. Learn its operation, application, and specific limitations.
- Support workpiece with miter gauge, work stop or worktable.
- Maintain 1/16" maximum clearance between table and sanding belt.

⚠ CAUTION

Think safety! Safety is always a combination of operator common sense and alertness when tool is being used.

⚠ WARNING

Do not attempt to operate tool until it is completely assembled according to instructions.

SPECIFICATIONS

Model number	9681106
HP	1.5
Voltage	115/230
Amps AC	7/3.5
Belt size	2" x 72"
Belt SFPM	1800-5000
Drive Wheel Ø	8"
Idler wheel Ø	4"
Wheel RPM	900-2400
Arbor hole	1"
Buffer diameter	10"
Buffer Width Min-Max	1"-5"
Weight	116 lbs

ASSEMBLY/INSTALLATION

Machine Dimensions

Figure 1 shows the approximate dimensions of the belt grinder. When determining a final location, ensure there is enough clearance for using the belt grinder in its various configurations. Also, consider the size of the work pieces that may require extra space.

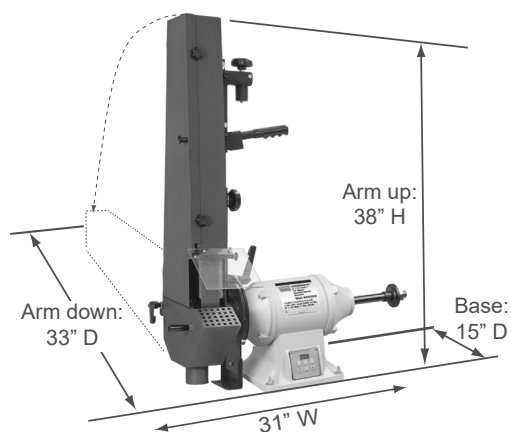

Figure 1. Dimensions

This machine requires some assembly. The support brackets, eye-shields, and lower dust collection guards must be attached before use.

CAUTION

Do not attempt assembly if parts are missing. Use this manual to order repair parts.

Location

The belt grinder must be installed on a structurally stable work surface. If in doubt, consult a qualified structural engineer.

- The belt grinder must be bolted to a firm, level surface.
- Ensure there is enough room for the grinder's arm to move through the full range of motion, fully upright and extending 28" to the rear.
- Ensure there is enough room around the belt grinder so that neither operator nor bystanders will be in line with the workpiece while the machine is operating.
- Figure 2 shows the base dimensions and mounting footprint

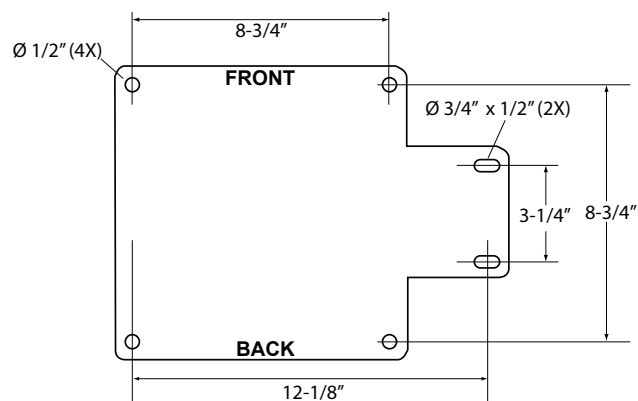

Figure 2. Base plate/support bracket footprint dimensions

Electrical Connections

WARNING

- Make sure tool is off and disconnected from power source when any maintenance is being performed or the belts are being replaced.
 - All electrical connections must be performed by a qualified electrician.
 - Ensure that the appropriate plug is installed for the line voltage in use.
 - Do not connect the belt grinder to the power source until all assembly steps have been completed.
1. The motor is designed for operation on the voltages and frequency specified.
 2. Normal loads will be handled safely on voltages not more than 10% above or below the specified voltage.
 3. Running the unit on voltages which are not within the range may cause overheating and motor burnout.
 4. Heavy loads require the voltage at motor terminals be not less than the voltage specified. Power supply to the motor is controlled by a single-pole locking rocker switch. Remove the key to prevent unauthorized use.

Support Bracket Assembly

1. Assemble the support bracket, using the provided plates, matching 3/8" screw and 3/8" washer and 3/8" spring washer on the motor side of the plate (shown in Figure 3).

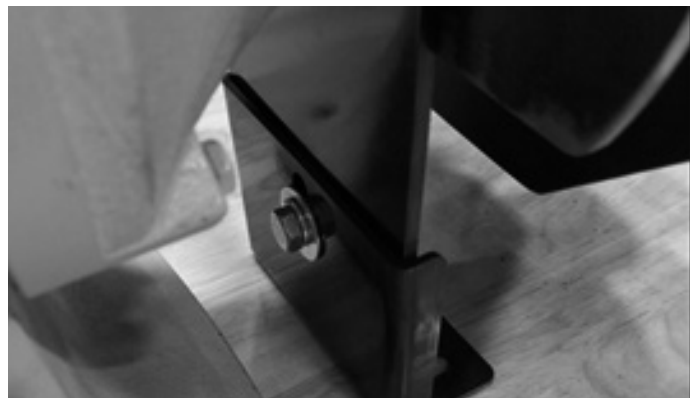

Figure 3. Support bracket, beneath left-side guard.

NOTE: Ensure that the foot of the plate faces away from the motor, as shown in Figure 3.

2. Install the plate on the inside of the pivot bracket.
3. Tighten the 3/8" screw into the pivot bracket that hangs from the motor casing.

WARNING

- Operation of any power tool can result in foreign objects being thrown into eyes which can result in severe eye damage. Always wear safety goggles complying with United States ANSI Z87.1 before commencing power tool operation.

OPERATION

Controls

- See Figure 4. To turn on press the “On/Off” button (bottom, center). The wheels will begin to spin. Pressing the button again turns OFF the machine.



Figure 4. Control buttons

- When ON, press the desired RPM buttons as shown below. The selected rpm value is displayed on the screen and the motor changes its rpm to match the selection.

RPM	SFPM
900	1850
1800	3750
2400	5000

- Pressing the “Dn” (down arrow) decrements the speed by 100 rpm. The minimum speed is 900 rpm.
- Pressing the “Up” (up arrow) increments the speed up by 100 rpm. The maximum speed is 2400 rpm.

Adjustment and Locking Handles and Knobs

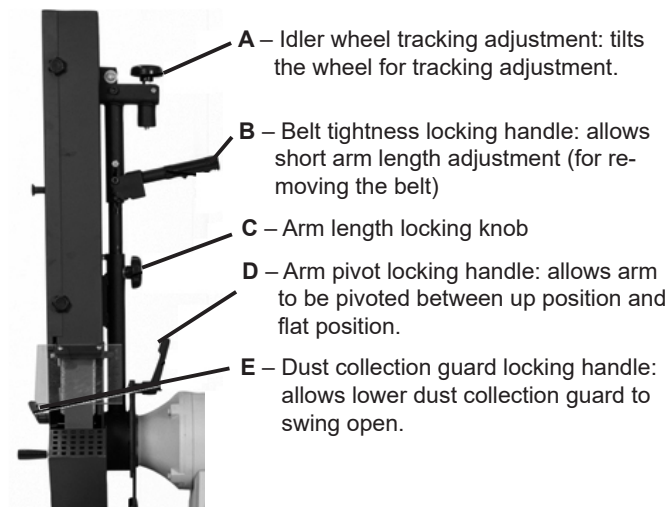

Figure 5. Handle identification

Removing And Replacing The Belt

To remove or replace the belt, follow these steps.

⚠ WARNING

Before starting, make sure to power down the belt grinder and unplug from the power source.

1. Put handle B (Figure 5) into locking position by pulling down. The idler wheel lowers, creating slack on the belt.
2. See Figure 6. Loosen handle F and knobs G and H to open the access panel.

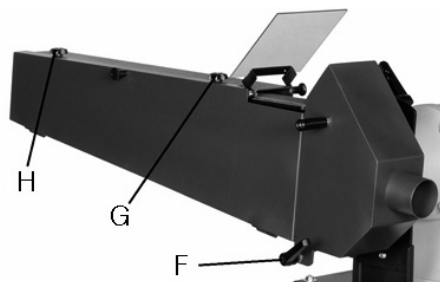

Figure 6. Access panel knobs and handles

3. Remove belt carefully. You may need to loosen the two platen handles, shown in Figure 7.

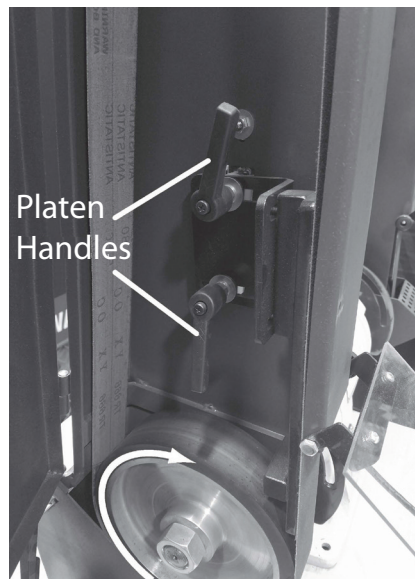

Figure 7. Inside belt guard

4. Replace the belt so it will run in the correct direction (downward, as seen from the front of the machine). The wheel rotates clockwise in operation as shown in Figure 7.
5. Re-align the platen, if it had been adjusted before.
6. Unlock Handle B (see Figure 5) to tension the belt.
7. Using your hand to rotate the wheel, adjust the belt tracking using knob A (see Figure 5).

TROUBLESHOOTING

Sympto,	Possible Causes	Corrective Action
Motor will not start	<ol style="list-style-type: none"> 1. Blown line fuse or tripped circuit breaker 2. Low line voltage 	<ol style="list-style-type: none"> 1. If fuse is blown, replace with fuse of proper size. If breaker tripped, reset it. 2. Check power supply for voltage and correct as needed.
Motor will not start; fuses blown or circuit breakers tripped	<ol style="list-style-type: none"> 1. Overloading due to binding 2. Defective plug 3. Defective cord 	<ol style="list-style-type: none"> 1. Clean around wheels and shaft and/or replace bearings 2. Replace plug 3. Replace cord
Motor fails to develop full power (power output of motor decreases rapidly with decrease in voltage at motor terminals)	<ol style="list-style-type: none"> 1. Power line overloaded with lights, appliances and other motors 2. Undersized wires or circuits too long 3. General overloading of power company's facilities 	<ol style="list-style-type: none"> 1. Reduce load on power line 2. Increase wire sizes, or reduce length of wiring 3. Request a voltage check from power company
Motor overheats	<ol style="list-style-type: none"> 1. Motor overloaded 2. Excess pressure when buffing 3. Buffing on side of wheel 4. Motor not turning freely when not powered 	<ol style="list-style-type: none"> 1. Reduce load on motor. 2. Replace wheel 3. Perform buffing only on wheel face 4. Clean around wheel and shaft and/or replace bearings
Motor stalls (resulting in blown fuses or tripped circuit breakers)	<ol style="list-style-type: none"> 1. Short circuit in motor or loose connections 2. Low voltage 3. Motor wired for different line voltage 4. Incorrect fuses or circuit breakers in power line 5. Motor overloaded 	<ol style="list-style-type: none"> 1. Inspect connections in motor for loose or shorted terminals or worn insulation on lead wires 2. Correct the low line voltage conditions 3. Rewire motor as per line voltage 4. Install correct fuses or circuit breakers 5. Reduce load on motor
Machine slows down while operating	Applying too much pressure to workpiece	Ease up on pressure
Abrasive belt runs off top wheel	Abrasive belt runs off top wheel	See "Removing And Replacing The Belt" on page 8"
Excessive vibration	<ol style="list-style-type: none"> 1. Improper mounting of belt 2. Improper belt wheel mounting 3. Improper mounting of buffer on buffer wheel 4. Buffing wheel not balanced 	<ol style="list-style-type: none"> 1. Align belt 2. Remount belt wheel 3. Remount buffer 4. Remount or replace buffer wheel
Buffer does not develop proper torque	Motor wired for different line voltage	Verify line voltage and the installed plug

GETTING STARTED

SAFETY / SPECIFICATIONS

ASSEMBLY / INSTALLATION

OPERATION

TROUBLESHOOTING

MAINTENANCE / REPAIR

PARTS LIST

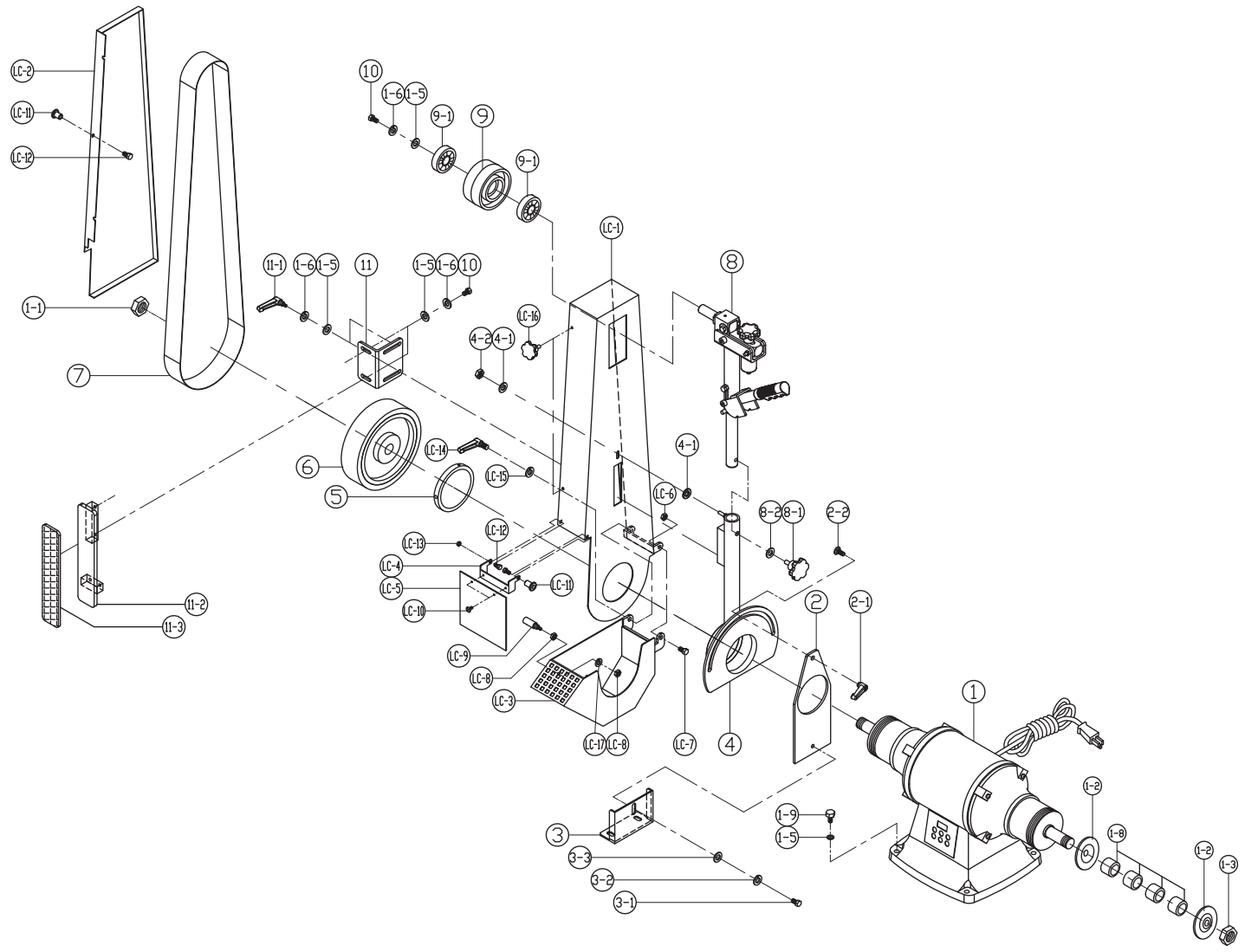

Figure 8. Belt Grinder Parts

Ref No.	Description	Part No	Qty
1	MOTOR	964982201	1
1-1	HEX NUT 1"-8UNC L.H.	*	1
1-2	WHEEL FLANGE	964982301	2
1-3	HEX NUT 1"-8UNC R.H.	*	1
1-4	HEX SCREW 5/16" X 1-3/4" L	*	4
1-5	WASHER 5/16"	*	13
1-6	SPRING WASHER	*	9
1-7	HEX NUT 5/16"	*	4
1-8	COLLAR 1" X 1"L	964982401	4
2	PIVOT BRACKET	964982501	1
2-1	LOCK LEVER 3/8"	964982601	1
2-2	CARRIAGE BOLT 3/8" X 3/4"L	*	1
3	PIVOT ARM MOUNTING BRACKET	964982701	1
3-1	HEX SCREW 3/8" X 3/4"L	*	1
3-2	SPRING WASHER 3/8"	*	1
3-3	WASHER 3/8"	*	1
4	PIVOT ARM	964982801	1
4-1	WASHER 1/4"	*	2
4-2	HEX NUT 1/4"	*	1
5	WHEEL FLANGE	964982901	1
6	DRIVE WHEEL	964983001	1
7	SANDING BELT 2" X 72" 100GR	964983101	1
8	AXLE ADJUSTABLE LEVER SET	964983201	1
8-1	KNOB 3/8" X 1"L	964983301	1
8-2	WASHER 3/8"	*	1
9	IDLER WHEEL	964983401	1
9-1	BEARING C&U 6204 RZ	964983501	2
10	HEX SCREW 5/16" X 5/8"L	*	3
11	PLATEN BRACKET	964983601	1
11-1	LOCK LEVER 5/16" X 3/4"L	964983701	2
11-2	PLATEN	964983801	1
11-3	GRAPHITE PAD 2"W X 9"L	964983901	1
LC-1	WHEEL GUARD	964951801	1
LC-2	WHEEL GUARD DOOR	964951901	1
LC-3	DUST CHUTE	964952001	1
LC-4	ADJUSTABLE PLATE	964952101	1
LC-5	PLASTIC COVER	964952201	1
LC-6	NYLON HEX NUT 3/8	*	1
LC-7	HEX SCREW 3/8" X 3/4"L	*	1
LC-8	HEX NUT 5/16"	*	1
LC-9	HANDLE 5/16"	964952301	1
LC-10	PHILLIPS HEAD SCREW 3/16" X 1/4"L	*	2
LC-11	KNOB 1/4"	964952401	2
LC-12	SCREW 1/4" X 1/2"L	*	3
LC-13	NYLON HEX NUT 1/4"	*	1
LC-14	LOCK LEVER 3/8" X 1"L	964952501	1
LC-15	SPRING WASHER 3/8"	*	1
LC-16	KNOB 1/4" X 1/2"L	964952601	2

(*) Standard hardware item, available locally.

PALMGREN WARRANTY

C. H. Hanson / Palmgren warrants their products to be free of defects in material or workmanship. This warranty does not cover defects due directly or indirectly to misuse, abuse, normal wear and tear, failure to properly maintain the product, heated, ground or otherwise altered, or used for a purpose other than that for which it was intended.

The warranty does not cover expendable and/or wear part (i.e. v-belts, screws, abrasives, jaws), damage to tools arising from alteration, abuse or use other than their intended purpose, packing and freight. The duration of this warranty is expressly limited to the terms noted below beginning from the date of delivery to the original user.

The Palmgren branded items carry the following warranties on parts:

All vises, clamps, positioning tables, arbor presses, tombstones, jack screws and vise accessories - LIFETIME.

All bench grinders, drill presses, tapping machines, band saws, lathes, milling machines, abrasive finishing machines and work stands - 3 YEARS.

The obligation of C.H. Hanson / Palmgren is limited solely to the repair or replacement, at our option, at its factory or authorized repair agent of any part that should prove inoperable. Purchaser must lubricate and maintain the product under normal operating conditions at all times. Prior to operation become familiar with product and the included materials, i.e. warnings, cautions and manuals.

Failure to follow these instructions will void the warranty.

This warranty is the purchaser's exclusive remedy against C.H. Hanson for any inoperable parts in its product. Under no circumstances is C.H. Hanson liable for any direct, indirect, incidental, special or consequential damages including loss of profits in any way related to the use or inability to use our products. This warranty gives you specific legal rights which may vary from state to state.

PALMGREN®

*Palmgren - a C.H. Hanson Company
2000 N. Aurora Rd., Naperville, IL 60563 U.S.A.
or call 1-800-827-3398*