

PALMGREN[®]

POWERGRIND[™]

6" BENCH GRINDER



9682090 shown.

Read carefully and follow all safety rules and operating instructions before first use of this product.

DESCRIPTION

Palmgren Bench Grinders are equipped with a totally enclosed ball bearing motor. Armature assembly is dynamically balanced for smooth operation. Motor housing is compact so long pieces of work can press against both wheels without touching the motor frame. Removable wheel guards allow for easy changing of wheels. Two-way tool rests are adjustable for wheel wear and angle grinding. Grinders come complete with spark guards and safety eyeshields.

UNPACKING

Check for shipping damage. If damage has occurred, a claim must be filed with the carrier immediately. Check for completeness. Immediately report missing parts to dealer.

To be certain the grinding wheels have not been damaged in shipment, strike the edges slightly with a metal object. A ringing sound indicates a good wheel, but a dull noise may signal a fracture.

WARNING: If you suspect a wheel of being fractured, replace it immediately. Fractured wheels may shatter, causing serious injury.

SPECIFICATIONS

9682090, 6" Bench Grinder

Horsepower	1/4
Voltage	120
Amperes	2.5
Hertz	60
Phase	Single
RPM	1750
Rotation (viewed from left side)	Clockwise
Wheel Diameter	6"
Wheel Bore	1/2"

SAFETY RULES

WARNING: This product can expose you to chemicals including lead and cadmium which are known to the State of California to cause cancer and birth defects or other reproductive harm, and phthalates which are known to the State of California to cause birth defects or other reproductive harm. For more information go to <http://www.p65warnings.ca.gov>.

WARNING: Some dust, fumes and gases created by power sanding, sawing, grinding, drilling, welding and other construction activities contain chemicals known to the State of California to cause cancer and birth defects or other reproductive harm. Some examples of these chemicals are:

- Lead from lead based paint
- Crystalline silica from bricks, cement and other masonry products
- Arsenic and chromium from chemically treated lumber

Your risk of exposure varies, depending on how often you do this type of work. To reduce your exposure to these chemicals, work in a well-ventilated area and work with approved safety equipment, such as dust masks that are specifically designed to filter out microscopic particles. For more information go to <http://www.p65warnings.ca.gov/> and <http://www.p65warnings.ca.gov/wood>.

BE PREPARED FOR JOB

- Wear proper apparel. Do not wear loose clothing, gloves, neckties, rings, bracelets or other jewelry which may get caught in moving parts of machine.
- Wear protective hair covering to contain long hair.

- Wear safety shoes with non-slip soles.
- Wear safety glasses complying with United States ANSI Z87.1. Everyday glasses have only impact resistant lenses. They are NOT safety glasses.
- Wear face mask or dust mask if operation is dusty.
- Be alert and think clearly. Never operate power tools when tired, intoxicated or when taking medications that cause drowsiness.

PREPARE WORK AREA FOR JOB

- Keep work area clean. Cluttered work areas and work benches invite accidents.
- Do not use power tools in dangerous environments. Do not use power tools in damp or wet locations. Do not expose power tools to rain.
- Work area should be properly lighted.
- Proper electrical plug should be plugged directly into properly grounded, three-prong receptacle.
- Extension cords should have a grounding prong and the three wires of the extension cord should be of the correct gauge.
- Keep visitors at a safe distance from work area.
- Keep children out of the workplace. Make workshop childproof. Use padlocks, master switches or remove switch keys to prevent any unintentional use of power tools.

TOOL SHOULD BE MAINTAINED

- Always unplug tool prior to inspection.
- Consult manual for specific maintaining and adjusting procedures.
- Keep tool clean for safest operation.
- Remove adjusting tools. Form habit of checking to see that adjusting tools are removed before turning machine on.
- Keep all parts in working order. Check to determine that the guard or other parts will operate properly and perform their intended function.
- Check for damaged parts. Check for alignment of moving parts, binding of moving parts, breakage of parts, mounting and any other condition that may affect a tool's operation.
- A guard or other part that is damaged should be properly repaired or replaced. Do not perform makeshift repairs. (Use the parts list to order replacement parts.)

KNOW HOW TO USE TOOL

- Use right tool for job. Do not force tool or attachment to do a job for which it was not designed.
- Disconnect tool from power when changing accessories such as grinding wheels, buffing wheels and the like.
- Avoid accidental start-up. Make sure that the switch is in the off position before plugging in.
- Do not force tool. It will work most efficiently at the rate for which it was designed.
- Keep hands away from moving parts and grinding surfaces.
- Never leave a tool running unattended. Turn the power off and do not leave tool until it comes to a complete stop.
- Do not overreach. Keep proper footing and balance.
- Never stand on tool. Serious injury could occur if tool is tipped over.
- Know your tool. Learn the tool's operation, application and specific limitations.
- Use recommended accessories. Understand and obey all safety instructions supplied with accessories. The use of improper accessories may cause risk of injury to persons.
- Do not over tighten wheel nut. Replace cracked wheel immediately. Use only flanges supplied with the grinder.

SAFETY RULES (CONTINUED)

- Adjust distance between wheel and tool rest to maintain 1/16" or less gap.
- Handle the workpiece correctly. Whenever possible, use tool rest to support workpiece during grinding operation. Turn tool off if it jams.
- Always use guards and eyeshields.
- Clean grinding dust from beneath tool frequently.

ASSEMBLY

Parts to be fastened to the unit should be located and accounted for before assembly.

IMPORTANT: Do not attempt assembly if parts are missing. Use this manual to order replacement parts.

- A Knob (2)
- B Flat washer, M8 (6)
- C Tool rest bracket (2)
- D Tool rest (2)
- E M10 Flat washer (2)
- F Knob (2)
- G Pan head screw, M5 x 10 (4)
- H Upper eyeshield bracket (2)
- I Eyeshield (2)
- J Lower eyeshield bracket (2)
- K Knob (2)
- L Spark Deflector (2)
- M Knob (2)
- N Spring Washer, M10 (8)

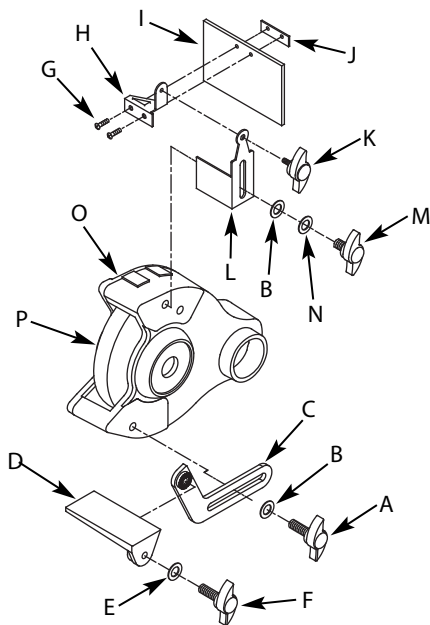

Figure 1 – Left Tool Rest and Eyeshield Assembly

TOOL REST ASSEMBLY

- 1) Place tool rest (D) over tool rest bracket (C) and secure in position with knob (F) and flat washer (E).
- 2) Attach tool rest bracket (C) to the bottom of the wheel guard (O) using knob (A) and flat washer (B). Make sure that the slot of the bracket is located over the raised boss on the wheel guard. Secure in position with knob.
- 3) Position tool rest (D) so that distance between tool rest (D) and

wheel (P) is less than 1/16". Reposition angle of tool rest if necessary. Secure all knobs.

- Mount right tool rest in a similar manner.

EYESHIELD ASSEMBLY

- Attach spark guard (L) to left wheel guard (O) using knob (M), spring washer (N) and flat washer (B).
- Mount left upper eyeshield bracket (H) to eyeshield (I) and lower eyeshield bracket (J) using two pan head screws (G).

NOTE: Left upper eyeshield bracket is stamped "L" for identification.

- Slide knob (K) through hole at top of left spark deflector (L) into upper eyeshield bracket (H) and secure in position.
- Locate eyeshield in desired position for protecting operator and secure all knobs and bolts.
- Mount right eyeshield assembly in a similar manner.

DUST COLLECTION HOSE

- A dust collector hose has been provided with grinder. Slide hoses onto sides of T-connector and flanges. Mount the hose by sliding the flanges at each end over the exhaust ports on the left and right wheel guards. Attach 2½" shop vacuum hose to collector hose. Be sure hose is mounted securely.

DANGER: Be sure to empty shop vacuum of all flammable material (flammable liquids and vapors, paper, wood, plastic, etc.) before connecting vacuum to grinder. Hot sparks from grinder may ignite flammable materials in shop vacuum.

INSTALLATION**MOUNT GRINDER (FASTENERS NOT INCLUDED)**

- Mount grinder to a solid horizontal surface.
- To mount grinder to metal pedestal, align mounting holes with corresponding holes in pedestal. Insert a 1/4-20 x 1¼" hex head bolt with flat washer through base of grinder. From bottom of pedestal, place a 1/4" flat washer and 1/4"-20 hex nut onto the bolt. Tighten only until space between grinder base and pedestal is 1/8". Using second nut on each bolt, jam tighten against the first to prevent loosening by vibration.
- To mount grinder to wooden bench top, use 1/4 x 1¼" wood screws with flat washers beneath heads. Tighten screws until space between grinder base and bench top is 1/8".

GROUNDING INSTRUCTIONS

WARNING: Improper connection of equipment grounding conductor can result in the risk of electrical shock. Equipment should be grounded while in use to protect operator from electrical shock.

- Check with a qualified electrician if grounding instructions are not understood or if in doubt as to whether the tool is properly grounded.
- This grinder is equipped with an approved 3-conductor cord rated at 300V and a 3-prong, grounding type plug (See Figure 2) for your protection against shock hazards.
- Grounding plug should be plugged directly into a properly installed and grounded 3-prong grounding-type receptacle (See Figure 2).

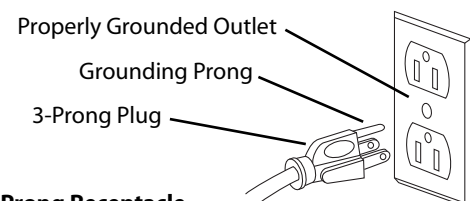

Figure 2 – 3-Prong Receptacle

INSTALLATION (CONTINUED)

- Do not remove or alter grounding prong in any manner. In the event of a malfunction or breakdown, grounding provides a path of least resistance for electrical shock.

WARNING: Do not permit fingers to touch the terminals of plug when installing or removing from outlet.

- Plug must be plugged into matching outlet that is properly installed and grounded in accordance with all local codes and ordinances. Do not modify plug provided. If it will not fit in outlet, have proper outlet installed by a qualified electrician.
- Inspect tool cords periodically, and, if damaged, have repaired by an authorized service facility.
- Green (or green and yellow) conductor in cord is the grounding wire. If repair or replacement of the electric cord or plug is necessary, do not connect the green (or green and yellow) wire to a live terminal.
- Where a 2-prong wall receptacle is encountered, it must be replaced with a properly grounded 3-prong receptacle installed in accordance with National Electric Code and local codes and ordinances.

WARNING: This work should be performed by a qualified electrician.

- A temporary 3-prong to 2-prong grounding adapter (See Figure 3) is available for connecting plugs to a two pole outlet if it is properly grounded.

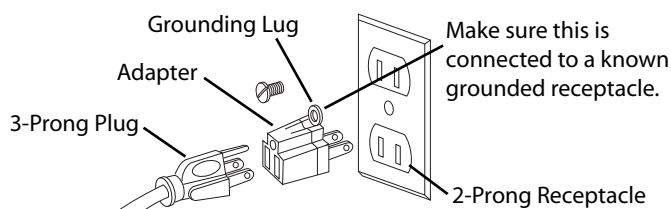

Figure 3 – 2-Prong Receptacle with Adapter

- Do not use a 3-prong to 2-prong grounding adapter unless permitted by local and national codes and ordinances. (A 3-prong to 2-prong grounding adapter is not permitted in Canada.) Where permitted, the rigid green tab or terminal on the side of the adapter must be securely connected to a permanent electrical ground such as a properly grounded water pipe, a properly grounded outlet box or a properly grounded wire system.
- Many cover plate screws, water pipes and outlet boxes are not properly grounded. To ensure proper ground, grounding means must be tested by a qualified electrician.

EXTENSION CORDS

- The use of any extension cord will cause some drop in voltage and loss of power.
- Wires of the extension cord must be of sufficient size to carry the current and maintain adequate voltage.
- Running the unit on voltages which are not within $\pm 10\%$ of the specified voltage may cause overheating and motor burn-out.
- Use the table to determine the minimum wire size (A.W.G.) extension cord.

Extension Cord Table					
Ampere Rating		Volts	Total Length of Cord in Feet		
		120	25	50	100
		240	50	100	200
			Minimum Gage for Cord		
More Than	Not More Than				
0	6		18	16	16
6	10		18	16	14
10	12		16	16	14
12	16		14	12	Not Recommended

- Use only 3-wire extension cords having 3-prong grounding type plugs and 3-pole receptacles which accept the tool plug.
- If the extension cord is worn, cut or damaged in any way, replace it immediately.

ELECTRICAL CONNECTIONS

WARNING: All electrical connections must be performed by a qualified electrician. Make sure tool is off and disconnected from power source while motor is mounted, connected, reconnected or anytime wiring is inspected.

- Motor and wires are installed as shown in wiring diagram (See Figure 4). Motor is assembled with approved, 3-conductor cord to be used at 120 volts. Motor is prewired at the factory for 120 volts.

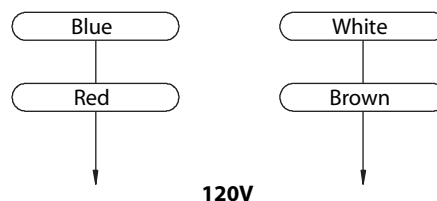

Figure 4 – Wiring Diagram

OPERATION

CAUTION: Always follow proper operating procedures as defined in this manual even if you are familiar with use of this or similar tools. Remember that being careless for even a fraction of a second can result in severe personal injury.

WARNING: Always wear safety glasses complying with United States ANSI Z87.1 (shown on package) before commencing power tool operation.

- Keep a steady, moderate pressure on the work and keep it moving at an even pace for smooth grinding.
- Pressing too hard overheats the motor and prematurely wears down the grinding wheels.
- Note the original bevel angle on the item to be sharpened and try to maintain that angle. Sharpening a cutting edge requires removing burrs from edge.
- Deburring edge is done best by using the grinder to pull burr from edge across the bevel angle.
- The grinding wheel should rotate into object being sharpened.
- Dip work into a coolant regularly to prevent overheating. Overheating can weaken metals.

MAINTENANCE

- As wheels wear, tool rests should be positioned closer to the face of the wheels.
- The gap between the wheel and the tool rest should not be greater than 1/16". When the wheels are worn to the extent that the 1/16" maximum gap cannot be maintained, the wheels should be replaced.
- Replacement wheels for model 9682090 must have a minimum rated speed of at least 1800 RPM and a maximum wheel diameter of 6".
- To loosen nuts holding the wheels, disconnect power and push a wood wedge between the tool rest and the wheel to keep the shaft from turning. The threads on the right side of the grinder (facing unit) are right hand; threads on the left side are left hand. Tighten nuts securely before operating the grinder.
- For grinding efficiency, wheels should be dressed periodically, especially if they become clogged from grinding soft metals.

TROUBLESHOOTING

SYMPTOM	POSSIBLE CAUSE(S)	CORRECTIVE ACTION
Grinder won't start	<ol style="list-style-type: none"> 1. Blown line fuse or tripped circuit breaker 2. Low line voltage 3. Material wedged between wheel and guard 4. Defective switch 5. Defective, blown capacitor 	<ol style="list-style-type: none"> 1. If fuse is blown, replace with fuse of proper size. If breaker tripped, reset it 2. Check power supply for voltage and correct as needed 3. Turn grinder off and remove material 4. Replace switch 5. Replace capacitor
Excessive vibration	<ol style="list-style-type: none"> 1. Improper mounting of grinder or accessories 2. Grinding wheel out of balance 3. Improper wheel mounting 	<ol style="list-style-type: none"> 1. Remount 2. Dress wheels or replace wheels 3. Remount wheels, but rotate one wheel 90° with respect to its previous position. Other wheel should remain in its original position
Motor overheating	<ol style="list-style-type: none"> 1. Excess pressure required to grind material 2. Grinding on side of wheel 3. Motor not turning freely (without power) 	<ol style="list-style-type: none"> 1. Dress wheel or replace wheel with one of proper grit 2. Grind only on face of wheel 3. Clean around wheels and shaft and/or replace bearings
Fuses are being blown or circuit breakers are being tripped	<ol style="list-style-type: none"> 1. Overloading due to binding 2. Defective plug 3. Defective cord 4. Defective switch 5. Faulty internal wiring 	<ol style="list-style-type: none"> 1. Clean around wheels and shaft and/or replace bearings 2. Replace plug 3. Replace cord 4. Replace switch 5. Contact your Palmgren distributor

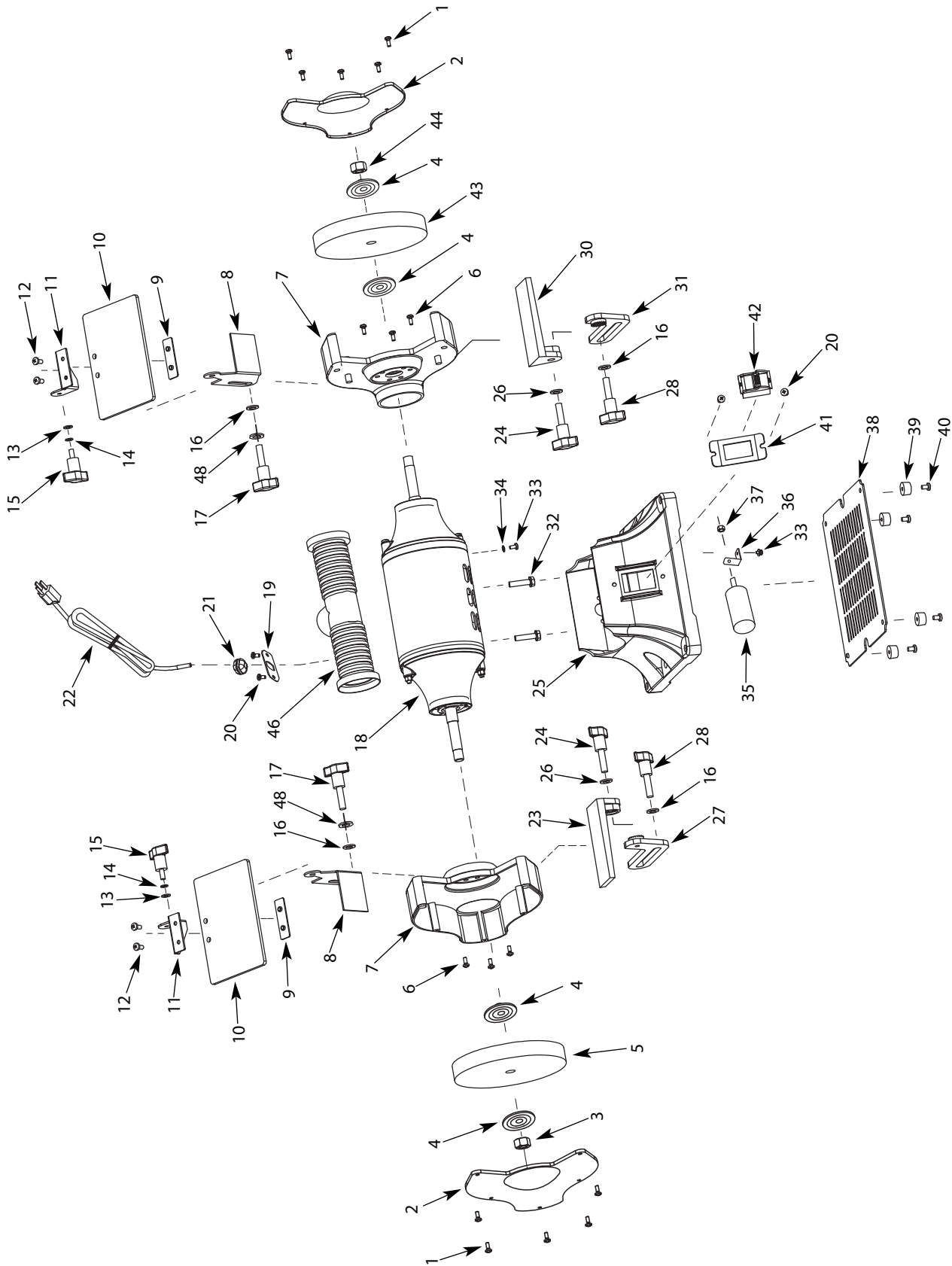

Figure 5 – Repair Parts Illustration for 9682090, 6" Bench Grinder

REPAIR PARTS LIST FOR 9682090, 6" BENCH GRINDER

Ref. No.	Description	Part Number	Qty.	Ref. No.	Description	Part Number	Qty.
1	Phillips Screw, Flat Washer, Spring Washer, M4x10	*	10	24	Locking Knob	9625812.01	2
2	Wheel Guard Cover	9624464.01	2	25	Base	N/A	1
3	Hex Nut, M12, LH Thread	9600064.01	1	26	Flat Washer, M8	*	2
4	Flange	9618904.00	4	27	Tool Rest Bracket, Left	9625810.01	1
5	Grinding Wheel, 36 Grit, 1/2" Bore	9602034.00	1	28	Locking Knob	9625817.01	2
6	Phillips Hex Bolt, Spring Washer, M6x14	*	6	30	Tool Rest, Right	9625825.01	1
7	Wheel Guard	9624465.01	2	31	Tool Rest Bracket, Right	9625826.01	1
8	Spark Deflector (Set of 2)	9616841.01	1	32	Phillips Screw, Spring Washer, M6x20	*	2
9	Eyeshield Plate	N/A	2	33	Phillips Screw, Spring Washer, Flat Washer, M4x8	*	2
10	Eyeshield Kit (Includes 9, 10, 12) Set of 2	9632290.01	1	34	Star Lock Washer, M4	*	1
11	Upper Eyeshield Bracket (Set of 2)	9625177.01	1	35	Capacitor	9616908.01	1
12	Phillips Screw, Spring Washer, M5x10	*	4	36	Capacitor Support	9616655.01	1
13	Flat Washer, M6	*	2	37	Hex Nut, M8	*	1
14	Spring Washer, M6	*	2	38	Base Plate	9623758.01	1
15	Eyeshield Knob	9625816.01	2	39	Rubber Foot	9623991.00	4
16	Flat Washer, M10	*	4	40	Phillips Screw, Flat Washer, M4x12	*	4
17	Spark Deflector Knob	9625817.01	2	41	Switch Plate	9636282.01	1
18	Motor	N/A	1	42	Switch	9608066.01	1
19	Clip Plate	9608099.01	1	43	Grinding Wheel, 60 Grit, 1/2" Bore	9602033.00	1
20	Phillips Screw, M5x8	*	4	44	Hex Nut, M12	9600548.01	1
21	Cord Clip	*	1	46	Dust Port Assembly	9608070.05	1
22	Power Cord	9600067.01	1	48	Spring Washer, M10	*	2
23	Left Tool Rest	9625813.01	1				

(A) Not shown.
 (N/A) Not available as repair part.
 (*) Standard hardware item, available locally.

PALMGREN WARRANTY

C.H. Hanson / Palmgren warrants their products to be free of defects in material or workmanship. This warranty does not cover defects due directly or indirectly to misuse, abuse, normal wear and tear, failure to properly maintain the product, heated, ground or otherwise altered, or used for a purpose other than that for which it was intended.

The warranty does not cover expendable and/or wear part (i.e. v-belts, screws, abrasives, jaws), damage to tools arising from alteration, abuse or use other than their intended purpose, packing and freight. The duration of this warranty is expressly limited to the terms noted below beginning from the date of delivery to the original user.

The Palmgren branded items carry the following warranties on parts:

All vises, clamps, positioning tables, tombstones, jack screws and vise accessories - LIFETIME.

All bench grinders, drill presses, tapping machines, band saws, lathes, milling machines, arbor presses, abrasive finishing machines and work stands - 3 YEARS.

The obligation of C.H. Hanson / Palmgren is limited solely to the repair or replacement, at our option, at its factory or authorized repair agent of any part that should prove inoperable. Purchaser must lubricate and maintain the product under normal operating conditions at all times. Prior to operation become familiar with product and the included materials, i.e. warnings, cautions and manuals.

Failure to follow these instructions will void the warranty.

This warranty is the purchaser's exclusive remedy against C.H. Hanson for any inoperable parts in its product. Under no circumstances is C.H. Hanson liable for any direct, indirect, incidental, special or consequential damages including loss of profits in any way related to the use or inability to use our products. This warranty gives you specific legal rights which may vary from state to state.

PALMGREN®

Palmgren - a C.H. Hanson Company
2000 N. Aurora Rd., Naperville, IL 60563 U.S.A.
or call 1-800-827-3398